

TM-72427

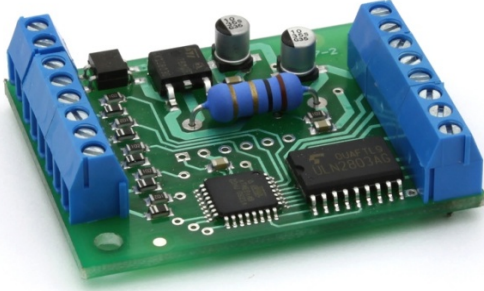

Railroad-crossing controller

User's manual



5 998975 300704



© 2011 BioDigit Ltd.

All rights reserved. It is forbidden to reproduce and/or publish the contents of the present document in any form including electronic and mechanical design without the written permission of BioDigit Ltd.



Safety warning

During the operation of the device the specified technical parameters shall always be met. At the installation the environment shall be fully taken into consideration. The device must not be exposed to moisture and direct sunshine.

A soldering tool may be necessary for the installation and/or mounting of the devices, which requires special care.

During the installation it shall be ensured that the bottom of the device should not contact with a conductive (e.g. metal) surface!

Contents

| | |
|-------------------------------------|---|
| Safety warning | 1 |
| Features and properties | 2 |
| Technical parameters | 2 |
| Short description | 2 |
| Inputs | 2 |
| Outputs | 3 |
| Installation | 3 |
| Guarantee and legal statement | 4 |

Features and properties

- Simple operation
- Realistic signalling and barrier delay
- Stop electromagnet outputs (Car system)
- Independent handling of two tracks per module
- Expandable to unlimited number of tracks

Technical parameters

Supply voltage: 7-24V AC/DC

Idle mode current consumption: 20 mA

Max. current consumption: 500 mA

Dimensions: 47x37 mm

Short description

The circuit enables the automatic operation of a light barrier and a lifting barrier on two tracks independent of each other. The track is passable from both directions and the module gives a "free" signal only in case if both tracks are released.

As the vehicle passes along the given track through the sensors (e.g. TM-73379: Reflective object sensor) it activates the red blinking signal whereafter also the barrier control output will be activated with a delay. As soon as the last carriage has left the given sensor, the barrier control output switches off then a "free" signal will be given also to the light barrier with a delay.

No direction distinction is required at the sensors along the given track section! Each sensor will automatically obtain a locking or release role.

Inputs

The module supply voltage is to be connected to the **POWER** input.

Module inputs can be activated by closing to the common point (GND). The **1A** and **1B** inputs receive signals from the first track, the **2A** and **2B** inputs from the second one.

In case the **EXT_IN** input is activated, the signal immediately changes to red. This input (together with the RED_OUT output of the previous module) enables the monitoring of more than two parallel tracks. See the wiring diagram.

Outputs

The light barrier is connected to the **RED** and **WHITE** outputs. If LEDs are used, serial current limiting resistors are required. See the wiring diagram.

The **RED_OUT** output activates when the red signal of the module is active. This output can be used to create a chain structure when more than two tracks are required to be monitored simultaneously. This output can be applied also in Car system for operating the stop-magnet placed in front of the railroad crossing.

The lifting barrier is connected to the **BARRIER_OUT** output. Simulating the real operation of the lifting barrier, the module activates the barrier with a delay when locking, and preliminarily when releasing.

On the **+V** output the rectified positive voltage is present (appr. 16-20V DC). This is a common point of the light barrier and the lifting barrier.

Installation

After wiring the circuit, when a sensor on the first track is activated, the signal has to change to red, which can be released only by another sensor on the same track.

If no release occurred, check the correct wiring to decide whether the sensors of the two tracks are interchanged!

Guarantee and legal statement

Each parameter of the device was submitted to comprehensive testing prior to marketing. The manufacturer undertakes one year guarantee for the product. Defects occurred during this period will be repaired by the manufacturer free of charge against the presentation of the invoice.

The validity of the guarantee will cease in case of improper usage and/or treatment.

Attention! By virtue of the European EMC directive the product can be used solely with devices provided with CE marking.

The mentioned standards and branch names are the trademarks of the firms concerned.

Figure 1:

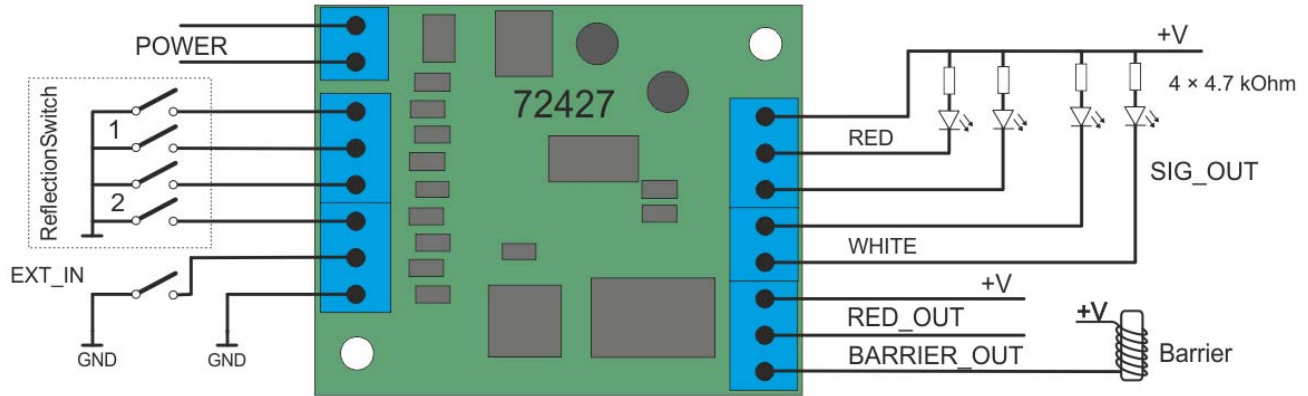

Figure 2: Summarized wiring diagram of the reflective sensors

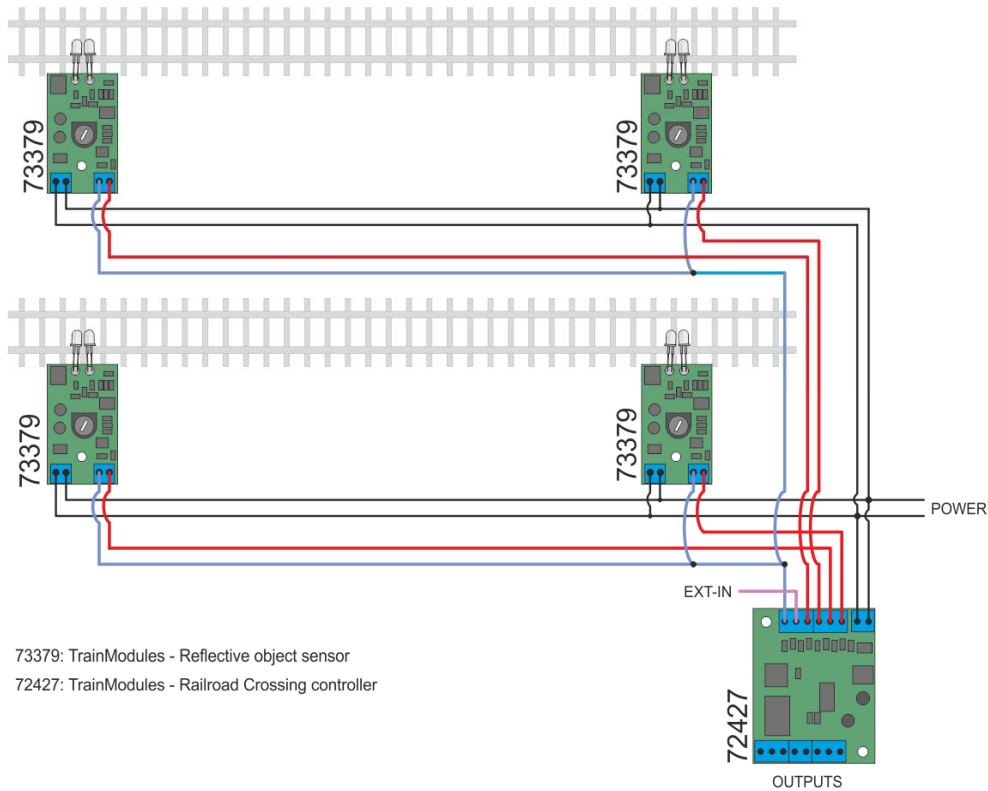

Figure 3: Chain arrangement in case more than two tracks are monitored

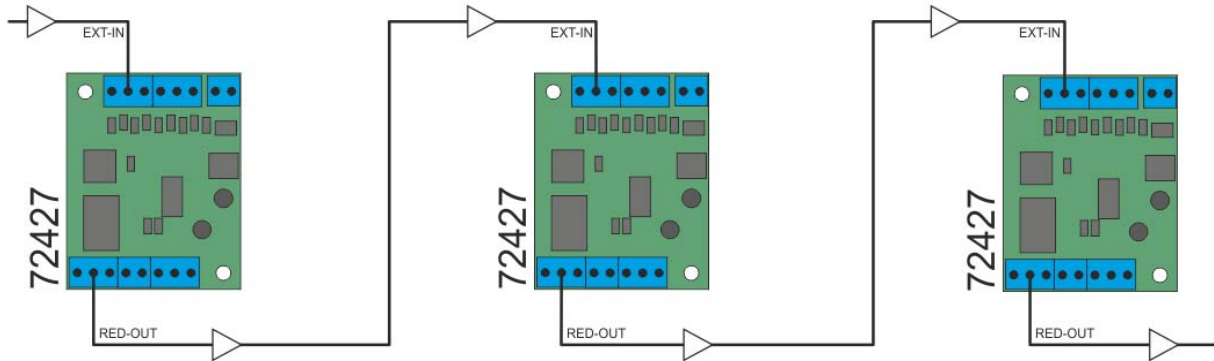
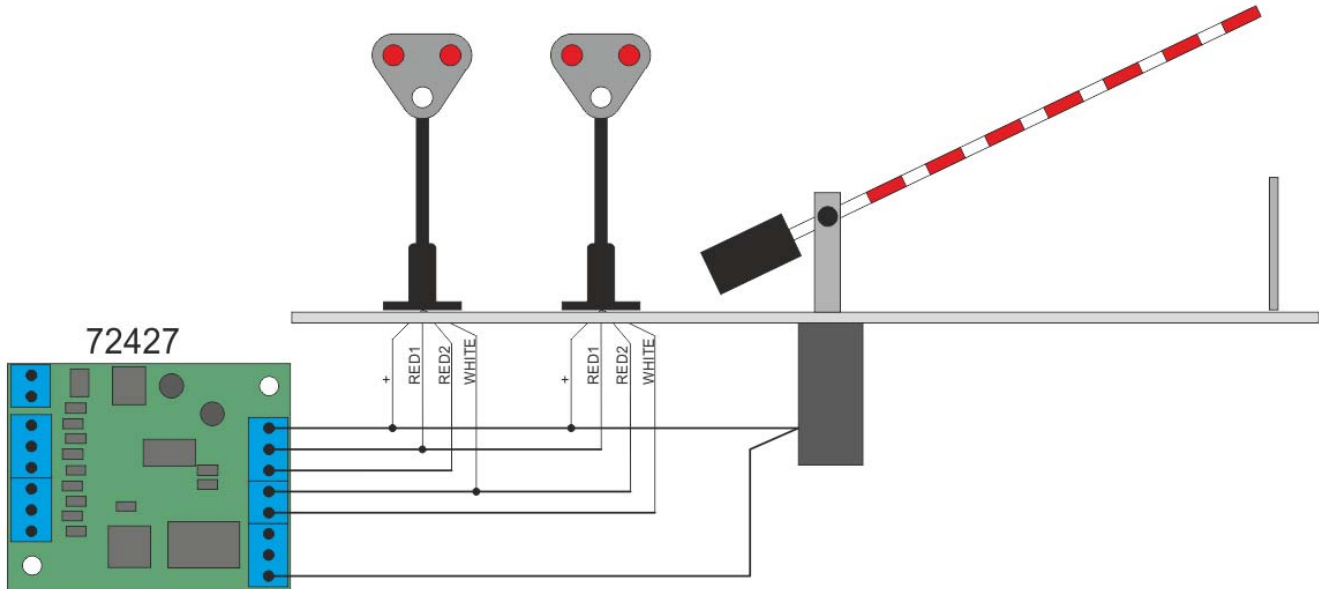

Figure 4: Wiring of the lifting barrier and the light barriers



* External serial resistors can be required for the light (e.g. 4,7KOhm 0,6W)